

# HORSE WHISPERER

QUILT 1

A Free Project Sheet  
NOT FOR RESALE



Featuring fabrics from the **Horse Whisperer** collection by **Kathleen Hill** for **STUDIO·e·fabrics**

## Quilt Fabric Requirements

(A) 5686P-13 .....	1 panel
(B) 1351-Brown**..	2/3 yard
(C) 5681-73 .....	1 1/8 yards*
(D) 5684-18 .....	1 yard
(E) 5685-13 .....	2/3 yard
(F) Charcoal-14+ .....	5/8 yard
(G) 5682-13 .....	1/3 yard
(H) 5678-07 .....	1/2 yard
(I) 5677-39 .....	2 yards
Backing	
5676-17 .....	4 3/4 yards

## Pillow Fabric Requirements

(A) 5685-13 .....	1/3 yard
(B) 1351-Brown**..	1/4 yard
(C) 5681-73 .....	1/4 yard
(D) 5679-17 .....	5/8 yard
(E) 5678-07 .....	1/4 yard

\* Includes Binding  
\*\* Just Color! Collection  
+ Peppered Cottons Collection

## Additional Supplies Needed

Batting 73" x 85" (Recommended:  
Air Lite® Colour Me 100% Cotton)  
Piecing and sewing thread  
Quilting and sewing supplies  
18" Pillow form

Quilt designed by Heidi Pridemore  
Finished Quilt Size 65" x 77"  
Finished Pillow Size 18" x 18"  
Skill Level: Advanced Beginner



## Fabrics in the Collection



Patchwork  
Multi - 5676-17



Running Horses  
Multi - 5677-39



Tossed Snowflakes  
Blue - 5678-07



Plaid  
Blue - 5679-17



Tossed Buckles  
Black - 5680-97



Paisley  
Multi - 5681-73



Tossed Horses  
Blue - 5682-13



Set Horses  
Blue - 5683-13



Border Stripe  
Multi - 5684-18



Horse Panel  
Multi - 5686P-13



Blocks  
Multi - 5685-13

## Select Fabrics from Just Color! and Peppered Cottons



Just Color!  
Brown  
1351-Brown



Peppered Cottons  
Charcoal  
Charcoal-14

## Quilt Cutting

### Cutting Instructions

*Please note: All strips are cut across the width of fabric (WOF) from selvage to selvage edge unless otherwise noted.*

WOF= Width of Fabric • LOF = Length of Fabric

#### **Fabric A (5686P-13 Horse Panel – Multi):**

- Fussy cut (1) 30 ½" x 42 ½" rectangle, centered on the panel.

#### **Fabric B (1351-Brown Just Color! – Brown), cut:**

- (2) 2" x 42 ½" WOF strips, piece as needed.
- (2) 2" x 33 ½" WOF strips.
- (4) 1 ¼" x WOF strips, sub-cut (8) 1 ¼" x 17 ½" strips.
- (3) 1 ¼" x WOF strips, sub-cut (8) 1 ¼" x 11 ½" strips.

#### **Fabric C (5681-73 Paisley – Multi), cut:**

- (4) 2 ¼" x WOF strips, sub-cut (8) 2 ¼" x 17 ½" strips.
- (3) 2 ¼" x WOF strips, sub-cut (8) 2 ¼" x 11 ½" strips.
- (8) 2 ½" x WOF strips for the binding.

#### **Fabric D (5684-18 Border Stripe – Multi), fussy cut:**

- (4) 5 ½" x 17 ½" strips, each entered on a barn stripe.
- (4) 5 ½" x 11 ½" strips, each entered on a barn stripe.

#### **Fabric E (5685-13 Blocks – Multi):**

- Fussy cut (6) 9" squares, each centered on a horse block.

#### **Fabric F (Charcoal-14 Peppered Cotton – Charcoal), cut:**

- (3) 2" x WOF strips, sub-cut (12) 2" x 9" strips.
- (4) 2" x WOF strips, sub-cut (12) 2" x 12" strips.
- (1) 1 ¼" x WOF strip, sub-cut (4) 1 ¼" x 10 ½" strips.
- (1) 1 ¼" x WOF strip, sub-cut (4) 1 ¼" x 9" strips.

#### **Fabric G (5682-13 Tossed Horses – Blue), cut:**

- (1) 9" x WOF strip, sub-cut (2) 9" squares.

#### **Fabric H (5678-07 Tossed Snowflakes – Blue), cut:**

- (4) 2" x WOF strips. Sew the strips together end to end with diagonal seams and cut (2) 2" x 64 ½" seams.
- (3) 2" x WOF strips. Sew the strips together end to end with diagonal seams and cut (2) 2" x 55 ½" seams.

#### **Fabric I (5677-39 Running Horses – Multi), cut:**

- (2) 5 ½" x 67 ½" LOF strips.
- From the remaining fabric, cut (2) 5 ½" x 65 ½" WOF strips, piece as needed.

#### **Backing (5676-17 Patchwork – Multi), cut:**

- (2) 85" x WOF strips. Sew the strips together and trim to 73" x 85" to make the back.

## Quilt Sewing

Sew using a  $\frac{1}{4}$ " seam allowance with right sides together (RST) unless otherwise indicated. Always press towards the darker fabric while assembling, unless otherwise noted by the arrows.

### Quilt Block Assembly

**Note: The arrows in figures represent the fabric print direction. Pay attention to the fabric and unit orientations when assembling the various components.**

1. Sew (1)  $2'' \times 42\frac{1}{2}''$  Fabric B strip to each side of the  $30\frac{1}{2}'' \times 42\frac{1}{2}''$  Fabric A panel. Sew (1)  $2'' \times 33\frac{1}{2}''$  Fabric B strip to the top and to the bottom of the Fabric A panel to make the Center Block (Fig. 1). **Trim the block to measure  $32\frac{1}{2}'' \times 44\frac{1}{2}''$ .**

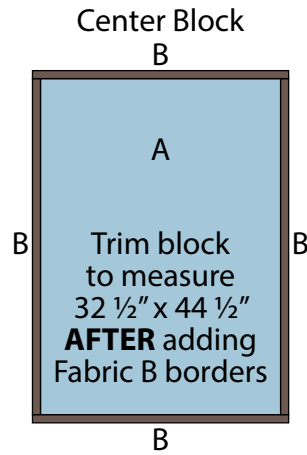

Fig. 1

2. Sew (1)  $2'' \times 9''$  Fabric F strip to each side of (1)  $9''$  Fabric E square. Sew (1)  $2'' \times 12''$  Fabric F strip to the top and to the bottom of the Fabric E square to make (1) Block One square (Fig. 2). **Trim the block to measure  $10\frac{1}{2}'' \times 10\frac{1}{2}''$ .** Repeat to make (6) Block One squares total.

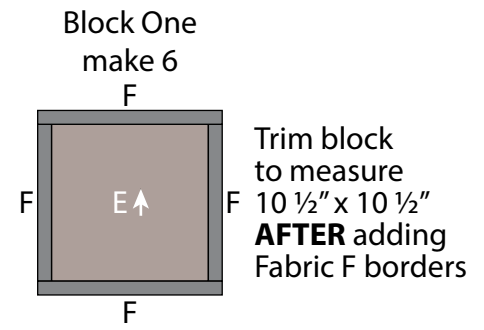

Fig. 2

3. Sew (1)  $1\frac{1}{4}'' \times 9''$  Fabric F strip to each side of (1)  $9''$  Fabric G square. Sew (1)  $1\frac{1}{4}'' \times 10\frac{1}{2}''$  Fabric F strip to the top and to the bottom of the Fabric G square to make (1) Block Two square (Fig. 3). Repeat to make a second Block Two square.

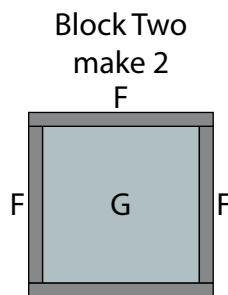

Fig. 3

4. Sew (1)  $1\frac{1}{4}'' \times 17\frac{1}{2}''$  Fabric B strip to the top and to the bottom of (1)  $5\frac{1}{2}'' \times 17\frac{1}{2}''$  Fabric D strip lengthwise. Sew (1)  $2\frac{1}{4}'' \times 17\frac{1}{2}''$  Fabric C strip to the top and to the bottom of the newly sewn strip lengthwise to make (1) Block Three rectangle (Fig. 4). Repeat to make (4) Block Three rectangles total.

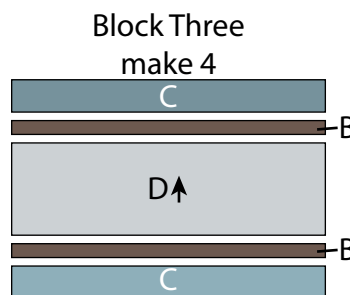

Fig. 4

5. Sew (1)  $1\frac{1}{4}'' \times 11\frac{1}{2}''$  Fabric B strip to the top and to the bottom of (1)  $5\frac{1}{2}'' \times 11\frac{1}{2}''$  Fabric D strip lengthwise. Sew (1)  $2\frac{1}{4}'' \times 11\frac{1}{2}''$  Fabric C strip to the top and to the bottom of the newly sewn strip lengthwise to make (1) Block Four rectangle (Fig. 5). Repeat to make (4) Block Four rectangles total.

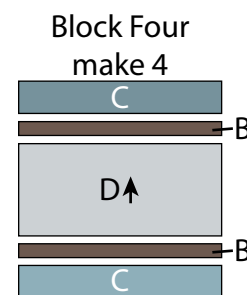

Fig. 5

6. Sew (1) Block Three rectangle to the top and to the bottom of (1) Block One square to make the Left Side Border (Fig. 6). Paying attention to the block orientations, repeat to make the Right Side Border (Fig. 7).

Left Side Border

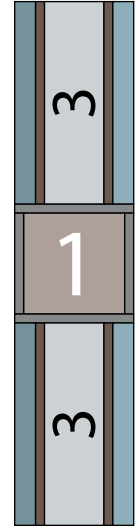

Fig. 6

Right Side Border

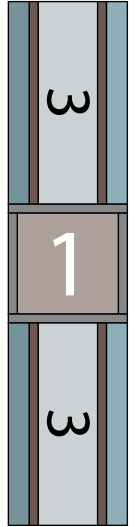

Fig. 7

7. Sew (1) Block Four rectangle to each side of (1) Block Two square. Sew (1) Block One square to each end of the newly sewn strip to make the Top Border (Fig. 8). Repeat to make the Bottom Border.

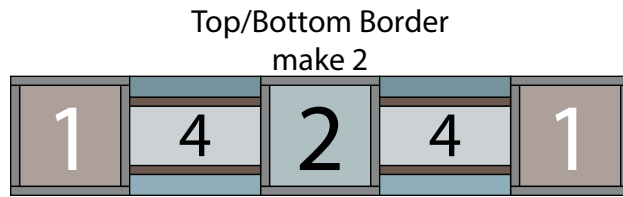

Fig. 8

## Quilt Top Assembly

*(Follow the Quilt Layout in Figure 9 while assembling the quilt top.)*

8. Sew (1) Side Border to each side of the Center Block. Sew the Top Border and Bottom Border to the top and to the bottom of the Center Block.

9. Sew (1) 2" x 64 1/2" Fabric H strip to each side of the Center Block. Sew (1) 2" x 55 1/2" Fabric H strip to the top and to the bottom of the Center Block.

10. Sew (1) 5 1/2" x 67 1/2" Fabric I strip to each side of the Center Block. Sew (1) 5 1/2" x 65 1/2" Fabric I strip to the top and to the bottom of the Center Block to make the quilt top.

## Layering, Quilting and Finishing

11. Press the quilt top and 73" x 85" backing well. Layer backing (wrong side up), batting, pressed quilt top (right side up) and baste. Quilt as desired and trim excess batting and backing when quilting is complete.

## Binding

12. Cut the ends of the (8) Fabric C binding strips at a 45-degree angle and sew end to end to make (1) continuous piece of binding. Fold in half lengthwise and press wrong sides together.

13. Sew the binding to the front of the quilt, raw edges together. Turn the folded edge to the back, and hand stitch in place.

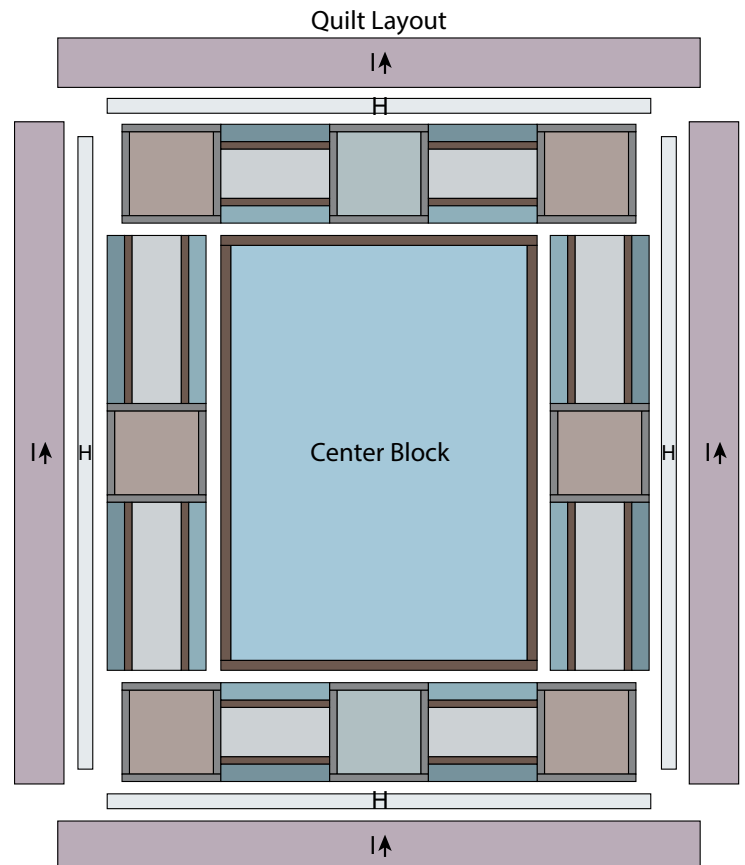

Fig. 9



## Pillow Quilt Cutting

### Pillow Cutting Instructions

*Please note: All strips are cut across the width of fabric (WOF) from selvage to selvage edge unless otherwise noted.*

WOF= Width of Fabric • LOF = Length of Fabric

#### Fabric A (5685-13 9" x 9" Blocks – Multi):

- Fussy cut (1) 9" square, centered on a horse block.

#### Fabric B (1351-Brown Just Color! – Brown), cut:

- (1) 2" x WOF strip, sub-cut (2) 2" x 9" strips.
- (1) 2" x WOF strip, sub-cut (2) 2" x 12" strips.

#### Fabric C (5681-73 Paisley – Multi), cut:

- (1) 1 ½" x WOF strip, sub-cut (2) 1 ½" x 12 ½" strips.
- (1) 1 ½" x WOF strip, sub-cut (2) 1 ½" x 10 ½" strips.

#### Fabric D (5679-17 Plaid – Blue), cut:

- (1) 13 ½" x WOF strip, sub-cut (2) 13 ½" x 18 ½" strips.
- (1) 3" x WOF strip, sub-cut (10) 3 ½" squares.

#### Fabric E (5678-07 Tossed Snowflakes – Blue), cut:

- (1) 3" x WOF strip, sub-cut (10) 3 ½" squares.

## Pillow Sewing

Sew using a ¼" seam allowance with right sides together (RST) unless otherwise indicated. Always press towards the darker fabric while assembling, unless otherwise noted by the arrows.

### Pillow Assembly

1. Sew (1) 2" x 9" Fabric B strip to each side of (1) 9" Fabric A square. Sew (1) 2" x 12" Fabric B strip to the top and to the bottom of the Fabric A square to make (1) Unit 1 square (Fig. 10). **Trim the block to measure 10 ½" x 10 ½"**.
2. Sew (1) 1 ½" x 10 ½" Fabric C strip to each side of the Unit 1 square. Sew (1) 1 ½" x 12 ½" Fabric C strip to the top and to the bottom of the Unit 1 square to make the Unit 2 square (Fig. 11).

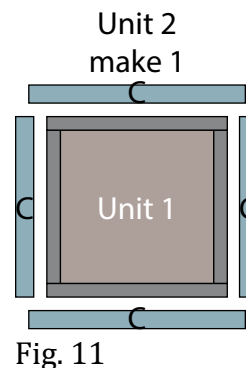
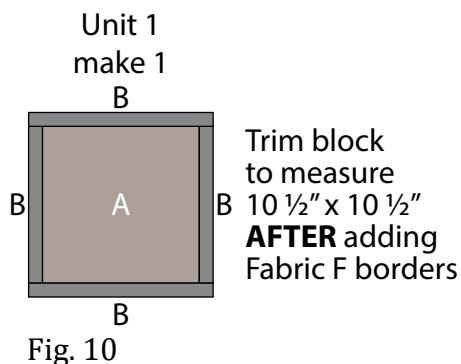

3. Sew together (2) 3 ½" Fabric E squares and (2) 3 ½" Fabric D squares, alternating them from top to bottom. Repeat to make a second strip. Sew (1) strip to each side of the Unit 2 square.
4. Sew together (2) 3 ½" Fabric E squares and (2) 3 ½" Fabric D squares, alternating them from left to right. Repeat to make a second strip. Sew the strips to the top and to the bottom of the Unit 2 square to make the Pillow top (Fig. 12).

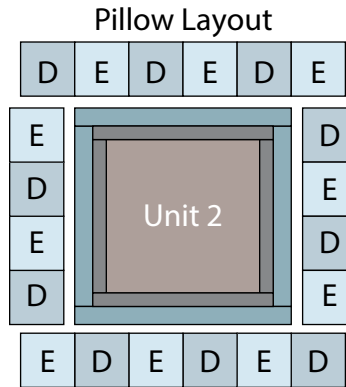

Fig. 12

5. Turn under the 18 ½" Fabric D edge approximately ¼", press and repeat to make a finished edge on one edge of the 13 ½" x 18 ½" Fabric D piece. Repeat with the second 13 ½" x 18 ½" Fabric D piece.
6. Position and pin the back envelope flap, right sides together with the pillow front, overlapping the finished edges in the middle and aligning the raw edges with the pillow front (Fig. 13). Stitch around the pillow front and back to complete the pillow.
7. Turn the pillow right side out.

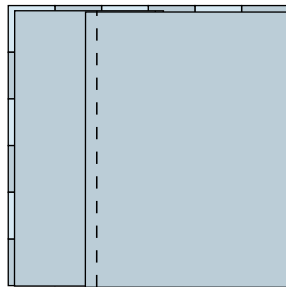

Fig. 13