

TIMELESS
TREASURES

BROOME STREET PATTERNS



Fly Away by *Janelle Penner*

Born to Fly

Designed by Kathryn Patterson



Finished quilt size: 68³/₈" x 68³/₈"

Fabric Requirements

1½ yards Echo-C5500 Water

1¾ yards Janelle-CM5622 Blue (includes binding)

½ yard Echo-C5500 Gold

¾ yard each:

Echo-C5500 Cream

Echo-C5500 Indigo

Fleur-C5629 Cream

Janelle-C5625 Cream

Janelle-C5626 Cream

Janelle-CM5621 Cream

Janelle-CM5628 Blue

Janelle-C5624 Aqua

Janelle-CM5621 Aqua

¼ yard Janelle-CM5622 Cream

½ yard Janelle-CM5622 Aqua

2¼ yards Janelle-CM5623 Mist

4⅓ yards Janelle backing fabric of your choice

Other supplies:

77" x 77" batting

Plastic template material

Cutting

From Echo-C5500 Water:

- Cut four 4" x width-of-fabric (WOF) strips. Sub-cut thirty-two 4" squares.
- Cut six 3¼" x WOF strips. Sub-cut sixty-four 3¼" squares.
- Cut ten 1½" x WOF strips. Sub-cut sixty-four 1½" x 6" strips.

From Janelle-CM5622 Blue:

- Cut two 4" x WOF strips. Sub-cut eighteen 4" squares.
- Cut three 3¼" x WOF strips. Sub-cut thirty-six 3¼" squares.
- Cut six 1½" x WOF strips. Sub-cut thirty-six 1½" x 6" strips.
- Cut eight 2½" x WOF strips for binding.

From Echo-C5500 Gold:

- Cut one 6¾" x WOF strip. Sub-cut four 6¾" squares. Cut each square once diagonally to make eight half-square triangles (HST).
- Cut one 4" x WOF strip. Sub-cut four 4" squares.
- Cut one 1½" x WOF strip. Sub-cut twenty-five 1½" squares.

From each of Echo-C5500 Cream, Echo-C5500 Indigo, Fleur-C5629 Cream, Janelle-C5625 Cream, Janelle-C5626 Cream, Janelle-CM5621 Cream and Janelle-CM5628 Blue:

- Cut one 6¾" x WOF strip. Sub-cut four 6¾" squares. Cut each square once diagonally to make eight HST.
- Cut one 4" x WOF strip. Sub-cut four 4" squares.

From each of Janelle-C5624 Aqua and Janelle-CM5621 Aqua:

- Cut one 6¾" x WOF strip. Sub-cut six 6¾" squares. Cut each square once diagonally to make twelve HST.
- Cut one 4" x WOF strip. Sub-cut six 4" squares.

From Janelle-CM5622 Cream:

- Cut one 6¾" x WOF strip. Sub-cut two 6¾" squares. Cut each square once diagonally to make four HST.
- From remainder of 6¾" strip, sub-cut two 4" squares.

From Janelle-CM5622 Aqua:

- Cut one 9¾" x WOF strip. Sub-cut two 9¾" squares. Cut each square once diagonally to make four corner triangles.
- From remainder of 9¾" strip, sub-cut four 4" squares.
- Cut one 6¾" x WOF strip. Sub-cut four 6¾" squares. Cut each square once diagonally to make eight HST.

From Janelle-CM5623 Mist:

- Fussy-cut twelve Template A setting triangles (see steps 6 and 7 for instructions).



Block Construction

All seam allowances are $\frac{1}{4}$ " and pieces are sewn right sides together.

Each block requires one set of two matching 4" squares, four $3\frac{1}{4}$ " squares and four $1\frac{1}{2}$ " x 6" strips; and one set of matching two $6\frac{3}{8}$ " squares cut into four HST, and two 4" squares; and one $1\frac{1}{2}$ " C5500 Gold square. Study the quilt image for fabrics combined in each block to duplicate the sample quilt exactly or pick your own combinations. Group patches into twenty-five block sets before beginning construction, and work with one set at a time.

1. From the first block set, draw two diagonal lines on the wrong side of each of the two lighter 4" squares. Place a marked square on a darker 4" square. Sew $\frac{1}{4}$ " seam on each side of one line. Cutting on unsewn line first, then on remaining drawn line, cut the sewn square into quarters. Open and press to make four pieced triangles, two of each orientation. Make eight triangles total, four of each orientation (figure 1).

Fig. 1

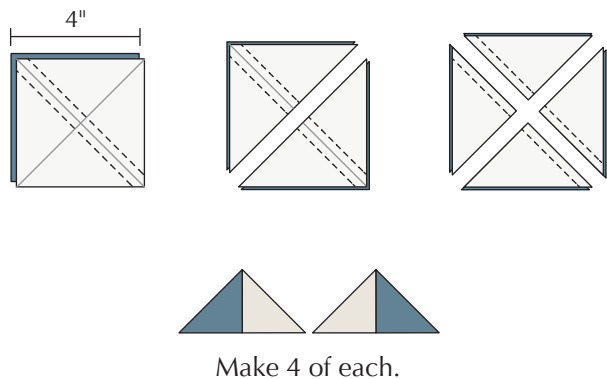

2. Sew a pieced triangle of each orientation to adjacent sides of a $3\frac{1}{4}$ " square to make large pieced triangle (figure 2). Make a total of four pieced triangles.

Fig. 2

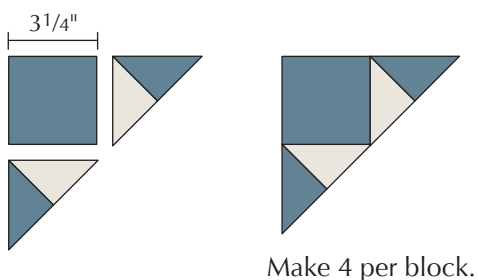

3. Sew a large pieced triangle and a $6\frac{3}{8}$ " HST together to make a quarter-block (figure 3). Make a total of four quarter-blocks.

Fig. 3

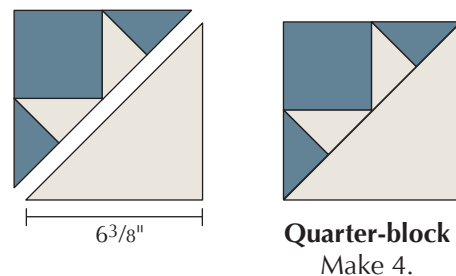

4. Following Figure 4, sew three rows using the four quarter-blocks, four $1\frac{1}{2}$ " x 6" strips and a $1\frac{1}{2}$ " C5500 Gold square. Sew the rows together to make the Cross and Crown Block.

Fig. 4

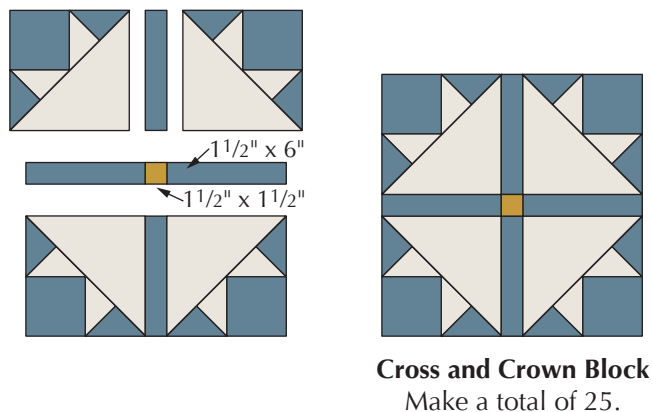

5. Repeat steps 1 through 4 to make a total of twenty-five blocks.

Quilt Top Assembly

Note: The setting triangles are cut slightly oversized to allow for trimming the quilt edges after assembly.

6. To make Template A, draw a $9\frac{1}{8}$ " x $18\frac{1}{4}$ " rectangle on the template plastic. Cut out the rectangle on the marked lines. Make a mark at the center of one long side. Draw lines connecting the rectangle corners

Fig. 5

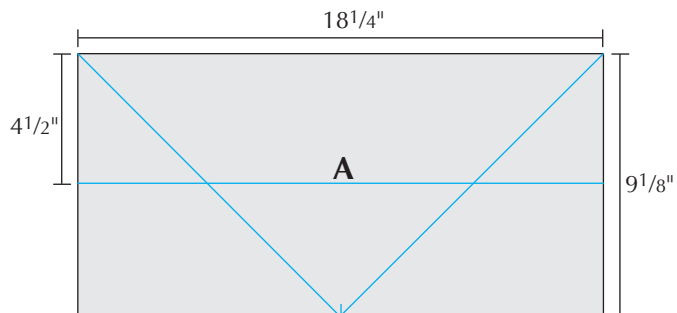

to the center mark. Measuring $4\frac{1}{2}$ " from top of template, mark a horizontal line. Cut out the large triangle (A) on the marked lines; discard the two smaller corner triangles (*figure 5*).

- Place Template A on a CM5623 Mist border print stripe, aligning the marked horizontal line on the template with the gold stripe beneath the picket fence in the print. Mark around the template; cut out the fabric triangle on the marked line (*figure 6*). Repeat to cut a total of twelve matching A triangles.

Fig. 6

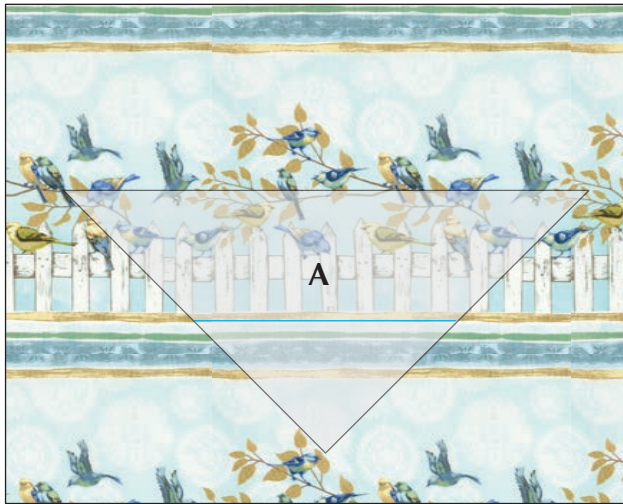

- Following the Quilt Assembly Diagram, lay out the blocks in diagonal rows, adding in the corner and setting triangles as shown.
- Sew the blocks and triangles together in each diagonal row, pressing the seams in alternate directions for adjacent rows.
- Sew the rows together in order, pressing the seams in the same direction. Trim the quilt edges evenly, $\frac{1}{4}$ " outside the outermost seam intersections.

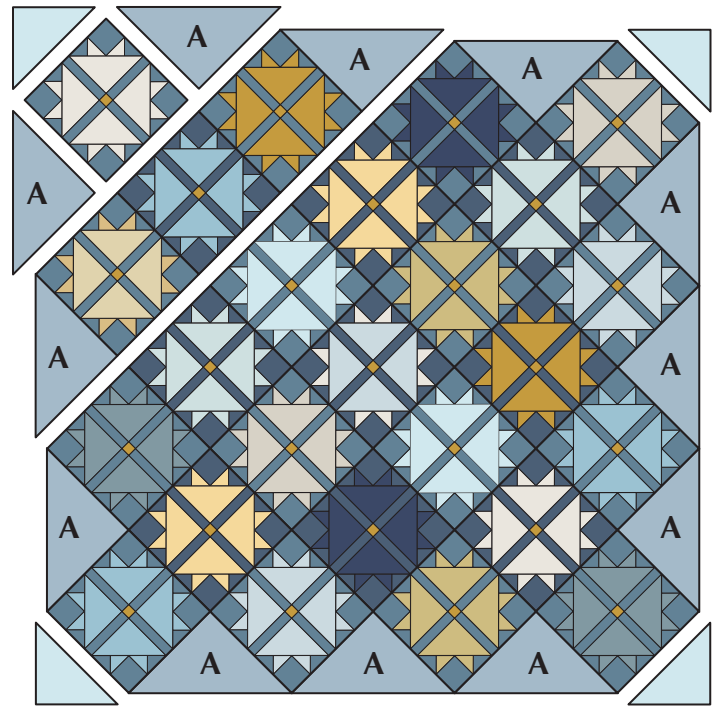

Quilt Assembly Diagram

Finishing

- Layer the quilt top, batting and backing, and quilt as desired.
- Stitch the binding strips together end to end using diagonal seams. Fold and press the resulting long strip in half lengthwise with wrong sides together. Stitch to the quilt front, matching raw edges and mitering the corners.
- Fold the binding to the quilt underside and hand-stitch the folded edge to the quilt back.

Kathryn Patterson
www.hillstreetquilts.com

©2017 Timeless Treasures www.ttfabrics.com
This pattern is for individual home use only. This pattern may not be reproduced for commercial purposes (i.e., may not be sold).



Imagination... Passion... Creativity