

Rhapsody in Gray



*83½" x 100" quilt designed by Monique Dillard
Gradiance fabric collection by Maywood Studio*

MAYWOOD  STUDIO

Cutting Fabric #1 for Kaleidoscope Triangles:

Note: Do not cut fabric #1 outer borders at this point. Outer borders will be cut in step 12.

1. From fabric #1, cut:

- 1 - 150" x WOF (Width Of Fabric) piece, into:
- 4 - 7" x 150" strips, as shown below:

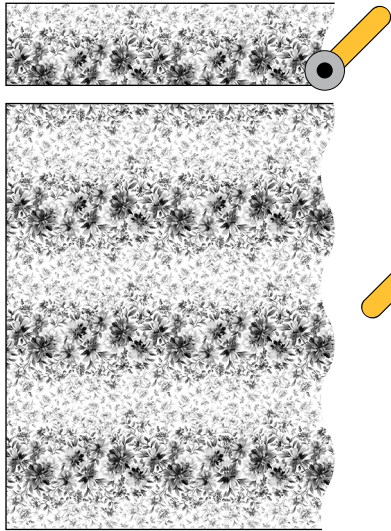

Cut first 7" x 150" strip as shown, just under the largest dark flowers.

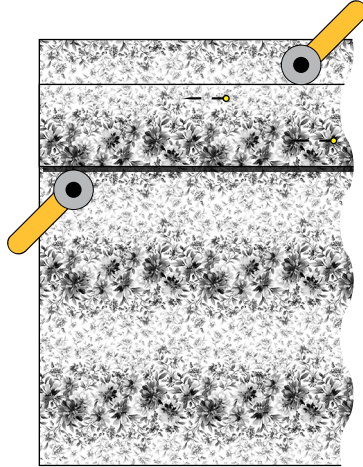

Place the first strip on top of the next stripe in the remaining fabric piece, using pins to match motifs and secure. Cut a second 7" strip by trimming the bottom layer of fabric along both edges of the first strip.

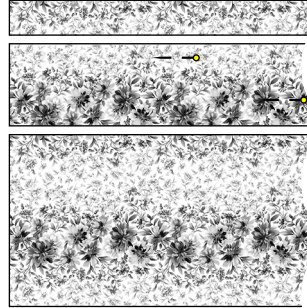

Repeat, moving the two cut strips on top of the next stripe to cut a third 7" strip.

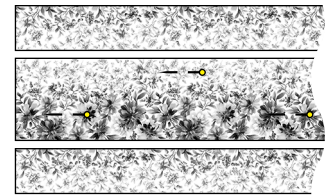

Repeat to cut a fourth 7" strip. You will now have a four-layer stack of identical 7" x 150" strips.

2. Keeping the 7" x 150" strips stacked, make 45° cuts to yield:

- Ten 4-triangle sets with light bases, and;
- Ten 4-triangle sets with dark bases (for a total of 80 fabric #1 triangles.)



Triangles are 14" wide at the base

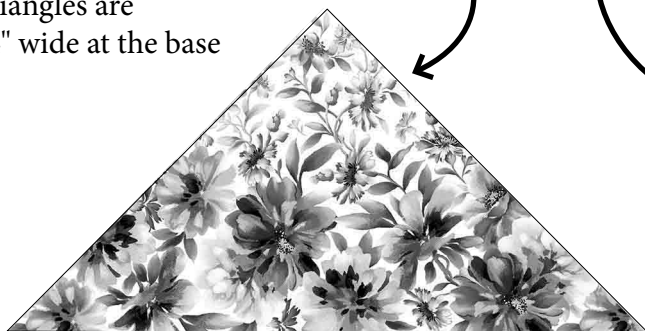

Dark-base Triangles
make 10 sets of 4
for Block A and Block B



Light-base triangles
make 10 sets of 4
for Block C and Block D

Triangle Sets

After cutting triangle sets, you may un-stack and rotate them to see their unique kaleidoscope effect. Keep each set of four triangles together when building your quilt blocks.

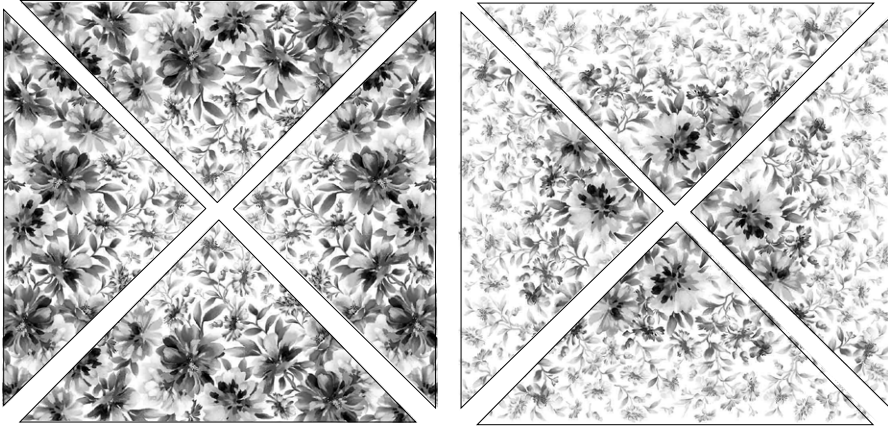

Fabric Groupings for Blocks:

3. Group fabric cuts with fabric #1 triangle sets as shown in the chart below.

BLOCK	FABRIC CUTS	DARK-BASE OR LIGHT-BASE TRIANGLE SETS
<p>A</p>	fabric #4 fabric #6	<p>5 Dark-base triangle sets</p>
<p>B</p>	fabric #5 fabric #7	<p>5 Dark-base triangle sets</p>
<p>C</p>	fabric #2 fabric #9	<p>5 Light-base triangle sets</p>
<p>D</p>	fabric #3 fabric #8	<p>5 Light-base triangle sets</p>

Piecing:

Follow instructions to make Block A. Repeat piecing steps with the other 3 groupings to make the remaining blocks.

4. Sew a 3½" x 20" strip of fabric #6 to the long end of the fabric #4 triangle. Repeat for a total of 20. Press half of the seam allowances toward fabric #6 and half away. Trim the two ends to make a triangle.



5. Using a dark-base triangle set, sew a step 4 unit to the base of a dark-base fabric #1 triangle, as shown. Repeat with the remaining three dark-base triangles to make 4 blocks. Press half the seam allowances toward fabric #1 and half toward fabric #6. Square the blocks to 9 ½" square. (If the blocks measure less than 9 ½", find the smallest block and trim all of them to that size.) The outside edges of fabric #1 are bias; use spray starch to stabilize the edges.

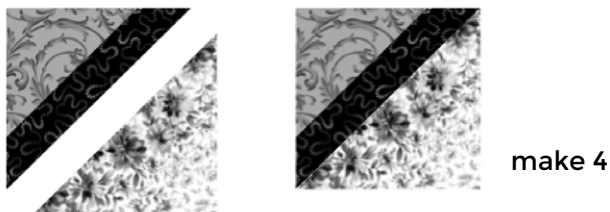

6. Sew the four matching units from step 5 together to make a Block A. Press in the direction of the arrows. Repeat to make a total of 5 Block A.

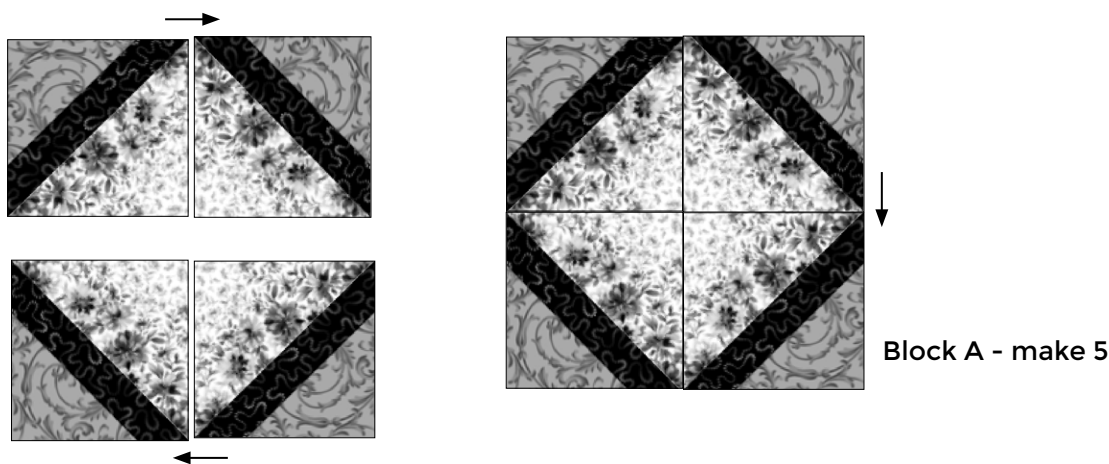

7. Repeat steps 4-6 for Blocks B, C and D (using fabric groupings in step 3 chart) for a total of 20 blocks.

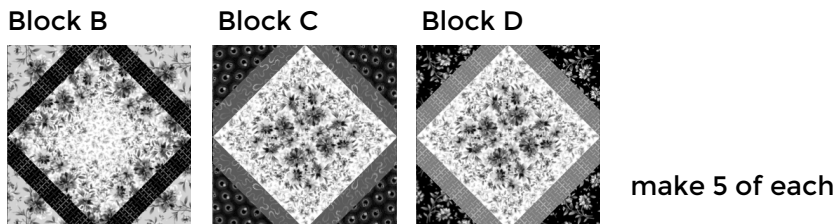

8. Square all 20 blocks to 18" including seam allowances. If the blocks are smaller, find the smallest block and trim all blocks to that size.

9. Sew the quilt center together with five rows of four blocks each as shown in the quilt diagram below. Press the rows in opposite directions and the quilt top rows down.

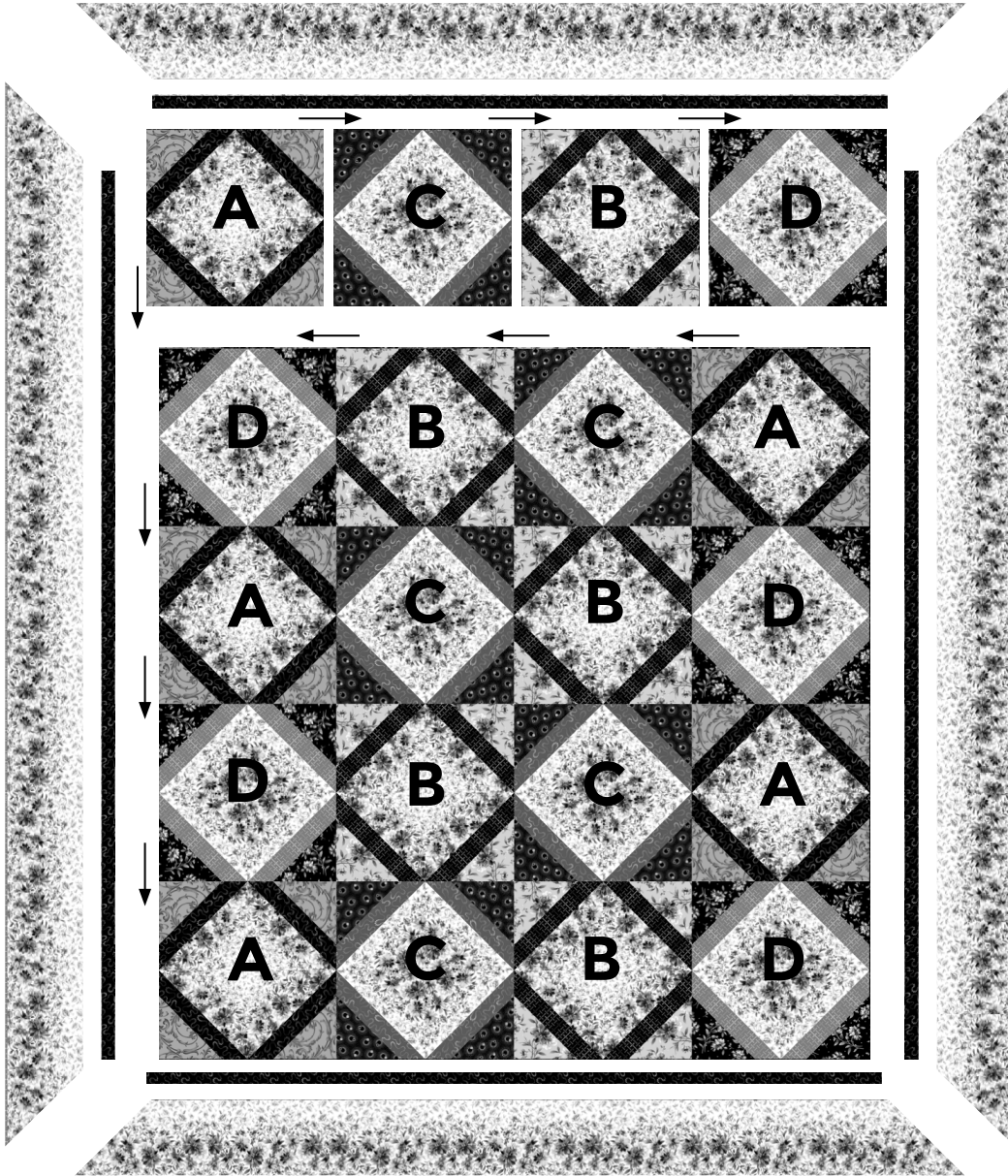

Inner Borders:

10. Sew two fabric #10 strips together to make one inner border strip. Repeat to make a total of 4 inner border strips. Measure the sides of the quilt center, trim two border strips to that length and sew to the sides of the quilt center.

11. Measure the width of the quilt top. Trim remaining inner border strips to that length and sew to top and bottom of quilt.

Outer Borders:

12. Measure the sides of the quilt top. Add 13" to that length and cut four 6½" outer border strips lengthwise from fabric #1. (For dark/light stripe cutting suggestion, see first illustration, step 1.)

13. Sew outer borders to the quilt top, mitering corners (see page 5 for mitered border instructions).

14. Quilt, bind and enjoy!

Mitered Borders Instructions

1. Fold the quilt top in half lengthwise. Place a straight pin at each fold to mark the center. Fold the quilt top in half widthwise and pin at each fold. Fold each border strip in half and pin at the folds.

2. Center the long border strips on the opposite long sides of the quilt RST by matching pinned center points. Repin layers together. Sew the border to the quilt top **starting and stopping 1/4" away from the edge of the quilt top edges**. Press toward darker fabric.

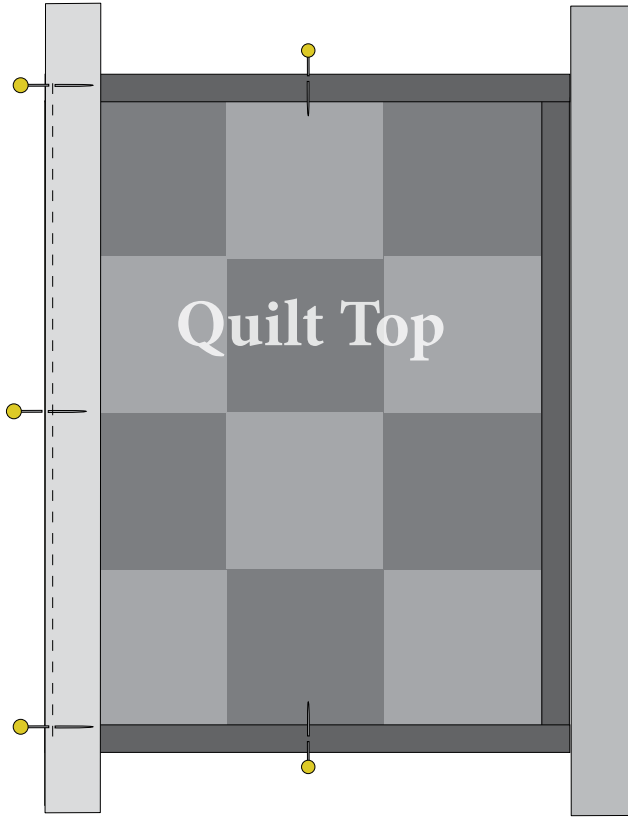

3. Place a short border strip onto the quilt top RST. Match the center points and repin.

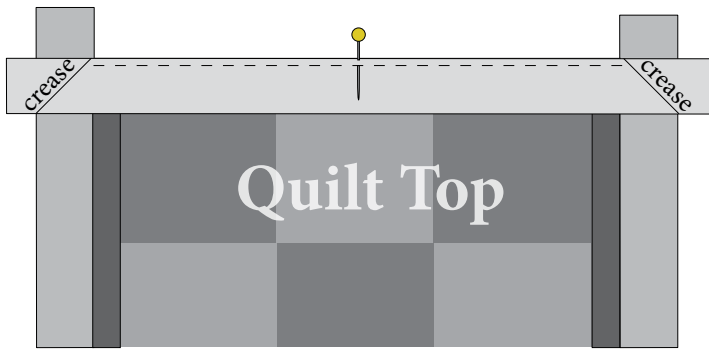

4. Press the ends of each short border strip at a 45° angle. Sew the short border strips to the top and bottom of the quilt. **Start and stop the stitches 1/4" away from the edges of the pieced top.**

5. Bring the short edges of the border strips together.

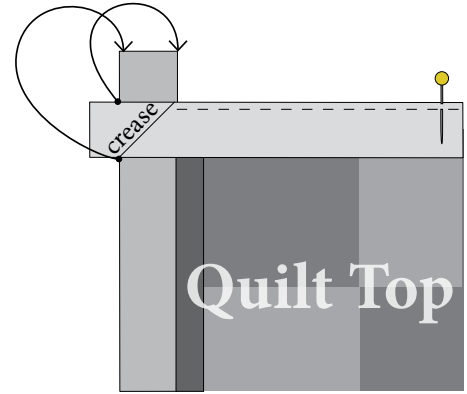



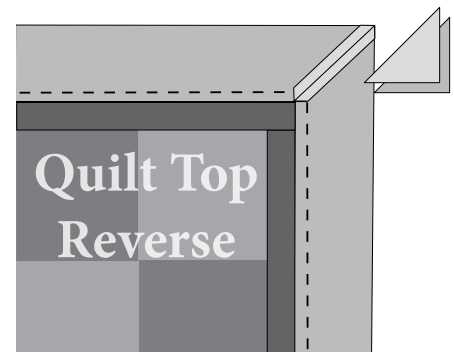



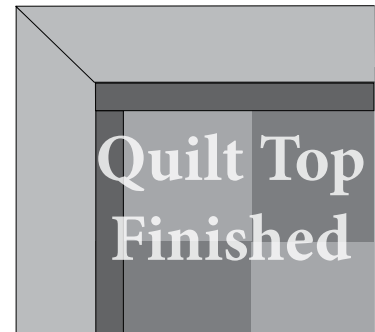

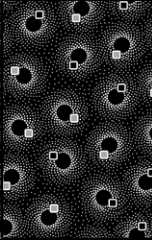
6. Sew along the pressed creases. Press open. Trim excess fabric.

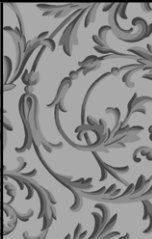

7. Repeat the process for the remaining corners.

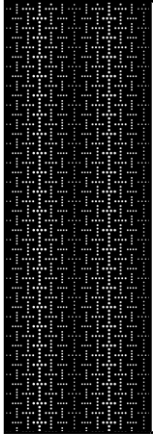
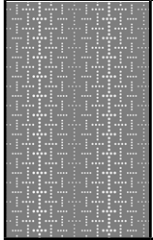

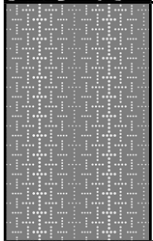
FABRIC		CUTTING
	Fabric 1 MAS8341-WKJ 7½ yds	From Fabric 1, cut: 4 — 6 ½" strips for outer borders (see step 12 for outer border cutting inst.) 4 — 7" x 150" strips, into: 80 — triangles for kaleidoscope blocks. (See detailed cutting instructions, step 1.)
	Fabric 2 MAS8346-J ¾ yd	From Fabric 2, cut: 2 — 7" strips, into: 10 — 7" squares, cut in half diagonally once
	Fabric 3 MAS8343-JK ¾ yd	From Fabric 3, cut: 2 — 7" strips, into: 10 — 7" squares, cut in half diagonally once
	Fabric 4 MAS8344-K ¾ yd	From Fabric 4, cut: 2 — 7" strips, into: 10 — 7" squares, cut in half diagonally once
	Fabric 5 MAS8343-K ¾ yd	From Fabric 5, cut: 2 — 7" strips, into: 10 — 7" squares, cut in half diagonally once
	Fabric 6 MAS8347-J 1 yd	From Fabric 6, cut: 10 — 2 ½" strips, into: 20 — 2 ½" x 21" strips

FABRIC		CUTTING
	Fabric 7 MAS8348-J 1 yd	From Fabric 7, cut: 10 — 2 ½" strips, into: 20 — 2 ½" x 21" strips
	Fabric 8 MAS8348-K 1 yd	From Fabric 8, cut: 10 — 2 ½" strips, into: 20 — 2 ½" x 21" strips
	Fabric 9 MAS8347-K 1 yd	From Fabric 9, cut: 10 — 2 ½" strips, into: 20 — 2 ½" x 21" strips
	Fabric 10 MAS8347-J ½ yd	From Fabric 10, cut: 8 — 2" strips for inner border
	Fabric 11 MAS8348-K ¾ yd	From Fabric 11, cut: 10 — 2 ½" strips for binding
	Backing YOUR CHOICE 7 yds	

Gradiance
fabric collection by Maywood Studio